

4

3

2

1

F

F

E

E

D

D

C

C

B

B

A

A

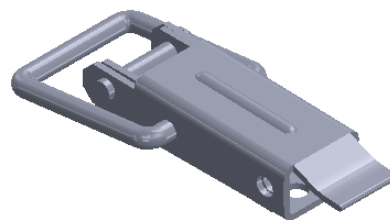
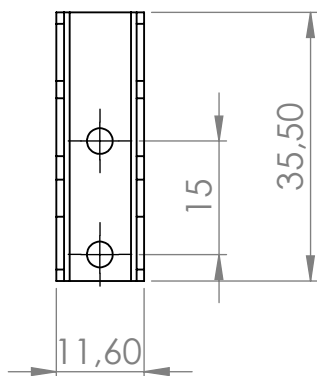
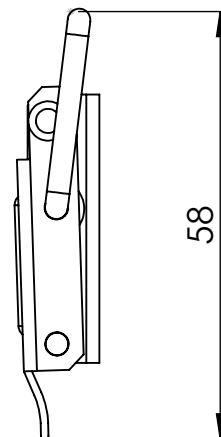
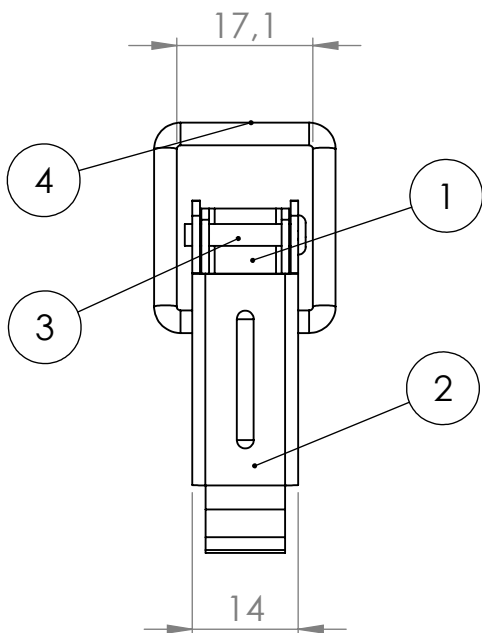

ITEM NO.	PART NUMBER	QTY.
1	Baseplate	1
2	Top part	1
3	Rivet	1
4	Bracket	1



FINISH: Zinc plated

DEBURR AND BREAK SHARP EDGES

REVISION

OJOP Sweden AB

NAME	SIGNATURE	DATE
DRAWN RR		22/5 - 17
CHKD PR		20/9 - 17
APPVD XXXX		XXXX
MFG XXXX		XXXX
Q.A XXXX		XXXX

MATERIAL: Steel

WEIGHT: 0,019 KG

TITLE: D10222 - 102 G2 ZP

DWG NO. D10222 - 102 G2 ZP

A4

SCALE:1:1

SHEET 1 OF 1

4

3

2

1